

Zip Hydrotap Boiling & Chilled BC120/65+S
c/w Satin Chrome Tap

Zip HydroTap®
 Instant Boiling and Chilled Filtered Water
 Under-Sink Commercial Models



Undersink Unit with filter compartment



Over-sized levers available for people with restricted dexterity (optional accessory)

Energy Conservation

A choice of two programmable energy saving modes –

- **Integral 24 hour 7 day timer** enables the boiling and chilled water units to switch off automatically during known periods of inactivity e.g. overnight or weekends, but return to full functionality ahead of the next expected demand.
- **Inactivity Sleep Mode** enables the boiling water unit to power down or switch off after 2 hours of non-use. Powering down allows the water temperature to gradually reduce to 65°C, at which it is maintained. Upon further draw off boiling resumes.

Features

- Provides greater volumes of boiling and chilled water
- Provides Instant boiling water for tea, coffee and hot foods
- Instant filtered chilled drinking water from the same tap
- Integral triple action sub-micron filter
- Safety lock - if needed - requires finger/thumb operation
- Optional font allows installation away from the sink
- Boiling and chiller system housed in base unit
- Integral 24 hour, seven day timer
- Inactivity sleep mode
- Power-Pulse™ energy-saving technology
- Faster recovery provides a far greater number of cups of boiling water/hour
- 'Freeflow' feature ensures filtered water continues to flow, even after chilled capacity exceeded
- Capable of delivering a hot drink or glass of water every 3 seconds.

Zip HydroTap BC Series

Product Code	Maximum Boiling Cups/Hr	Maximum Chilled glasses/hour	Power Rating kW @ 230V	Dimensions (mm) W X D X H
BC120/65+S	120	60	2.3	385 X 380 X 348

Description

- Undersink instant boiling and chilled filtered water from the same tap
- Can be installed on a worktop or at a sink
- All components other than the tap in a single case with easy access to the filter
- Integral, fully encapsulated triple action submicron filter with optional scale filter system available
- Programmable maximum measured water delivery
- Safety lock provides additional user safety, where required
- Available in 2 capacities
- Cool touch tap
- Lock-on tap facility for filling larger vessels
- Filter replacement indicator
- Higher element ratings and enhanced software significantly increases boiling water recovery rates
- Free-Flow™ models offer continual supply of filtered when chilled water capacity is exceeded. However temperature will be less chilled until full recovery is achieved
- Undercounter safe tray with leak detector

Boiling system

Open outlet, vented system designed to operate at 98°C.

Chilling system

Fan-cooled condenser type, chilling from 5-10°C.

Refrigerant

R134A

Tap head

Chrome plated tap with electronic controls, integral safety lock and LED indicators.

Undersink system

White corrosion resistant enamelled steel case with front access door and control panel.

Approvals

WRAS approved and CE endorsed.

Warranty

1 year on-site parts and labour.
For full details visit [HYPERLINK](http://www.zipheaters.co.uk/warranty)
<http://www.zipheaters.co.uk/warranty>

Installation

Location

Should be installed either on a suitable sink or on a Zip Tap Font. If installing on a sink, the tap should be mounted so that it will dispense into the sink. The under-sink unit should be located, if possible, directly beneath the tap and not more than 1 metre away.

Plumbing

The water supply must be potable (drinkable).
If static pressure exceeds 7 bar, a pressure reducing valve needs to be fitted. An isolating valve should be installed between the supply and the unit.

Venting

A vent in the HydroTap may discharge small amounts of water or steam, so tap must be mounted where it can drain.

Ventilation—IMPORTANT

It is essential that the cupboard containing the undersink unit is adequately ventilated as poor air circulation will adversely affect the performance of the HydroTap. Cupboard doors must be offset all round using the 4mm buffers provided and the supplied vent fitted. If it is not possible to fit the vent in the cupboard door then consideration should be given to installing it in the side wall of the cupboard to dissipate heat to adjoining areas. Where limited ventilation is available it is strongly recommended that the optional auxiliary fan, ref: SP90651, is used. Supplied as standard on BC200//175+.

Electrical

To be wired to a double pole fused spur, minimum break capacity of 13 amps. Installation must comply with current IEE regulations.

Caution

In some hard water areas where mineral scale accumulation may be an issue, consideration should be given to the maintenance required. We recommend the use of the Zip Scale Filtration System.

Technical Support

Contact Zip on: 0800 077 8302.

Typical Installation

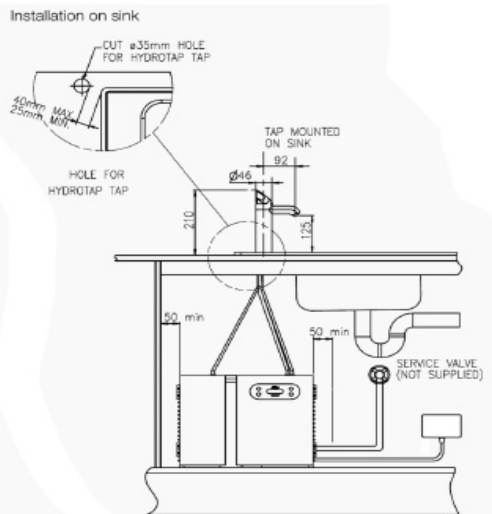

Minimum clearances (mm)

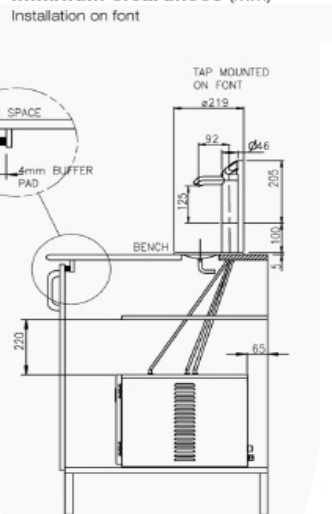

Dimensions

